

**ONE MORE FOLDED SUNSET: THE WINSTON OH TRAVELOGUE AWARD'S 20TH ANNIVERSARY EXHIBITION PRACTISING INNOVATION IN THE 21ST CENTURY**

Institute of Contemporary Arts Singapore  
 Brother Joseph McNally Gallery, Praxis Space and Project Space  
 LASALLE College of the Arts

6 September – 24 October

This exhibition celebrates 20 years of artists' travel and research enabled by Dr Winston Oh's generous patronage.

The Winston Oh Travelogue Award provides graduating students from the McNally School of Fine Arts the opportunity to pursue their practice abroad. In this exhibition, recipients of this year's award and 12 past awardees explore their journeys and encounters with places around the world.

Borrowing a phrase from Elizabeth Bishop's poem, *Questions of travel* (1965), *One more folded sunset* highlights the experiential processes of travel, as well as reflections about previous awardees' artistic journeys since they received the award.

Projects by the 10 recipients of this year's award will be presented in Praxis Space and Project Space from 6 September to 24 October.

Existing and new works by the 12 past awardees will be presented in Brother Joseph McNally Gallery from 18 September to 24 October.

**Recipients and destinations of the 2019 Winston Oh Travelogue Award**

Diploma: Azirah Binte Jamal (Indonesia), Cindy Sao (Myanmar), Muhammad Rusydan Bin Md Norr (Indonesia), Raigo Law Haizhi (Thailand), Sarah Lin Fang Yi (Vietnam)

BA(Hons): Loh Chan Hong (South Africa), Kara Inez Binti Saheran (India), Lai Yu Tong (Hong Kong)

MA: Paul Gerald Hurley (United Kingdom), Sufian Samsiyar (Germany)

**Selected past awardees (1999–2018)**

Avis Yeyoon, Eugene TYZ, Justin Lim, Kray Chen, Liyana Ali, Masuri Mazlan, Michelle Lim, Moses Tan, Rifqi Amirul Rosli, Shubigi Rao, Shazwany Aziz and Zaki Razak

Curator: Adeline Kueh  
 ICA Singapore coordinating curators: Melanie Pocock, Caterina Riva

**Brother Joseph McNally Gallery**

Dimensions are given height preceding width (followed, where applicable, by depth)

- 1 Michelle Lim  
*Pocketful of sunshine*, 2011  
 thread, coloured pencil and synthetic polymer paint on card  
 dimensions variable  
*Visitors are invited to handle the artwork.*
- 2 Shubigi Rao  
*The wood for the trees*, 2018  
 high-definition digital video, 16:9 aspect ratio, colour, sound  
 16:22 minutes
- 3 Justin Lim  
*Untitled (state of flux)*, 2019  
 oil on polyester; synthetic polymer paint on wooden stretcher  
 2 parts: (a) 50 x 70 x 4.5 cm, (b) 50 x 50 x 4.5 cm
- 4 Masuri Mazlan  
*in wilderness, into the ether*, 2019  
 spray paint and wall paint on polyurethane, canvas, coral, stones, crystals  
 2 parts: (a) 37 x 47 x 8 cm, (b) installation dimensions variable
- 5 Rifqi Amirul Rosli  
*Big fleet escapade*, 2019  
 silkscreen, collage and paper on wood panel  
 30 x 23 cm  
*Voyage something paradise*, 2019  
 silkscreen, collage, paper on wood panel  
 30 x 23 cm  
*Sunset 5*, 2019  
 monoprint  
 29 x 40 cm
- 6 Kray Chen  
*Johna*, 2019  
 high-definition digital video, 16:9 aspect ratio, colour, sound  
 7:51 minutes

- 7 Shazwany Aziz  
*Subsets*, 2018  
 paper collage, mixed media  
 8 parts: each 21 x 29.7 cm
- 8 Moses Tan  
*Breathe/seek/leave*, 2019  
 three-channel digital video installation:  
 (a) 9:16 aspect ratio, colour, sound;  
 (b) 16:9 aspect ratio, colour, sound; (c) digital video displayed on iPad from 7:00 pm to 12 noon, 4:3 aspect ratio, colour, sound; curtain, rail  
 (a) 2:47 minutes, (b) 2:47 minutes, (c) 9:32 minutes
- 9 Eugene TYZ  
*Enjoying clouds go by*, 2019  
 time-lapse digital video projection of found footage  
 17:47 minutes
- 10 Liyana Ali  
*An offset*, 2019  
 cement, plywood, office pins  
 8 parts: (a) 25 x 6 x 5.5 cm, (b) 26 x 5 x 6 cm, (c) 25 x 6.5 x 6 cm, (d) 26 x 6 x 4.5 cm, (e) 26 x 6 x 4.5 cm, (f) 26 x 5 x 5 cm
- 11 Yeyoon Ann Avis  
*Ragtime complexité\_\_ Regressive rhythm*, 2019  
 digital print on adhesive vinyl  
 50.5 x 250 x 60 cm
- 12 Zaki Razak  
*The night of more than a thousand months is better than one thousand and one nights*, 2019  
 silkscreen print on carpet  
 240 x 170 cm

*Visitors are invited to remove their shoes and move onto the mat.*

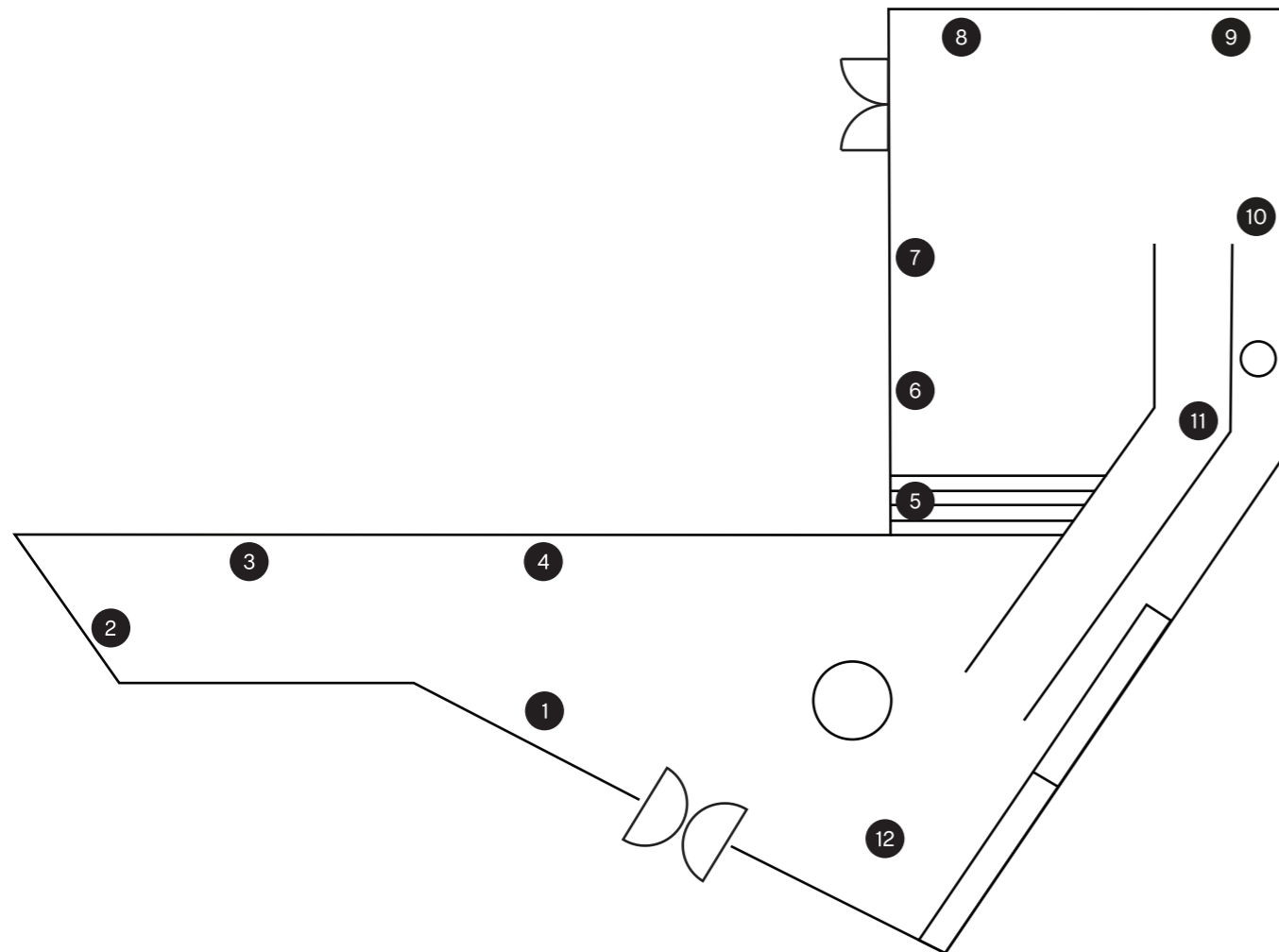

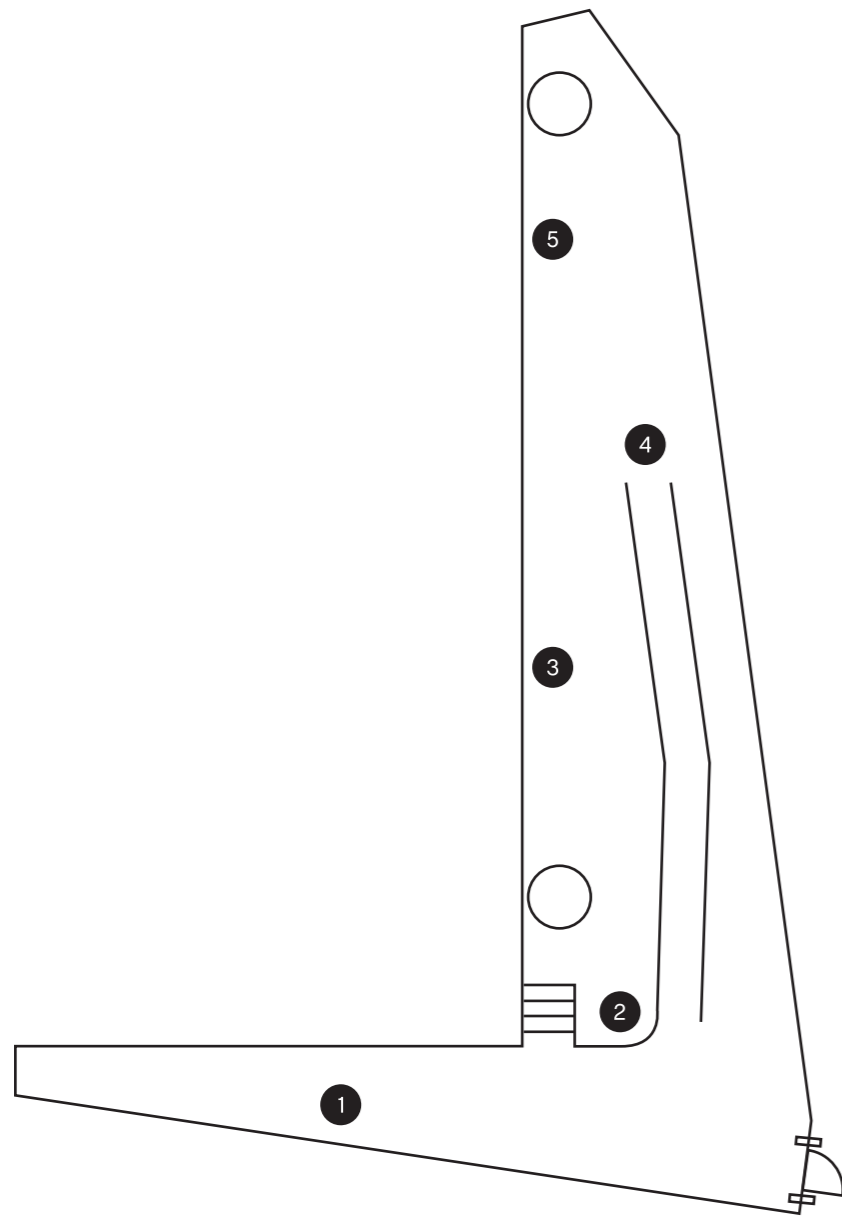

**Praxis Space**

- 1 Sufian Samsiyar  
*Dusk chorus*, 2019  
4-channel sound installation  
featuring Haffidz Razak  
137 minutes
- 2 Chan Hong  
*Wanderlings*, 2019  
plastic, cloth, duct tape, fabric  
overall dimensions variable  
high-definition digital video, 4:3 aspect ratio,  
colour, sound  
9:37 minutes
- 3 Cindy Sao  
*Repetitive enclosure*, 2019  
synthetic polymer paint, digital print, silver  
flakes, fishing net  
each canvas: 61 x 46 cm  
overall dimensions variable
- 4 Kara Inez Binti Saheran  
*Tirupati body threads*, 2019  
hair, plant, rock, twig, plastic  
overall dimensions variable
- 5 Sarah Lin  
*Inhale exhale*, 2019  
tarpaulin, synthetic polymer paint on wood,  
helmet, Pachira plants, bags, paper, LED  
overall dimensions variable

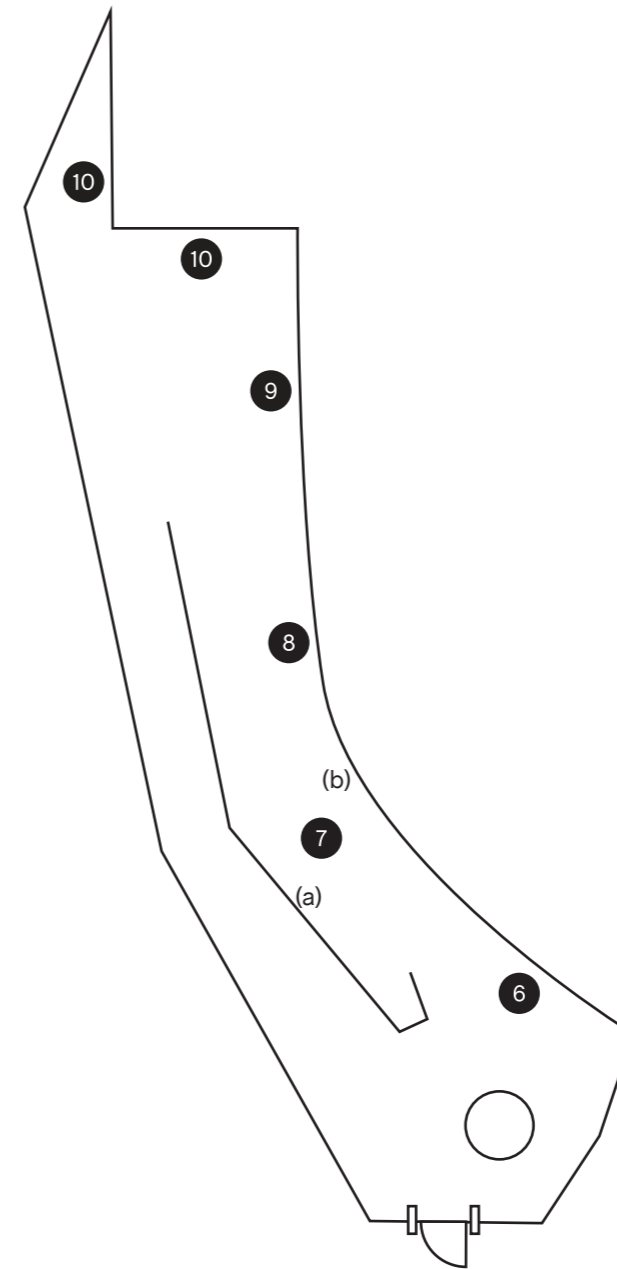

**Project Space**

- 6 Azirah Binte Jamal  
*Idiosyncratic*, 2019  
plates, cutlery, cloth, cushion  
overall dimensions variable  
Padang food; Padang place  
2 high-definition digital videos,  
16:9 aspect ratio, colour, sound  
4:42 minutes
- 7 Lai Yu Tong  
(a) *Objects taking sides*, 2019  
shampoo, conditioner, body soap, facial  
cleanser, toothpaste, hair gel, shaver, cigarette  
box, serviette  
overall dimensions variable  
(b) *A stinging feeling on my skin*, 2019  
digital video on iPhone, T-shirts, colour, sound  
11 minutes
- 8 Raigo Law  
*It's cumulative, not singular*, 2019  
digital print on PVC  
150 x 100 cm  
digital print on transparency  
29.7 x 21 cm
- 9 Muhammad Rusydan  
*There is sunlight*, 2019  
cyanotype on fabric, paper  
overall dimensions variable
- 10 Paul Hurley  
*Dan y dŵr [Under the water]*, 2019  
high-definition digital video projection,  
16:9 aspect ratio, colour, sound  
5 minutes  
maps of Wales, Welsh and Singaporean rocks  
overall dimensions variable

All works courtesy the artists