

TROPICAL LAB 11

CITATION: DÉJÀ VU

Institute of Contemporary Arts Singapore
Brother Joseph McNally Gallery, Praxis Space and Project Space
LASALLE College of the Arts
3 August – 6 September 2017

Artists: Alain Pezard, Ambra Viviani, Anna Diehl, Aphinya Watheephakdee, Brenda Tan, Caitlyn Wilson, Cheryl Chiu, Don Tinling, Duy Hoàng, Edi Danartono, Emily Clark-Kramer, Harryaldi, Jessie Wright, Julia König, Lizzy Simpson, Miho Otsuki, Nadja Büttner, Nandin-Erdene Budzagd, Pauline Fabry, Sara Stern, Satya Cipta, Stefan Tschumi, Uchiyama Shiori, Yu Chen, Yukino Okumura and Zoë Coughlan

Participating institutions: Academy of Media Arts Cologne, Academy of Art and Design Institute, FHNW Academy of Art and Design in Basel, California Institute of the Arts, Columbia University, Indonesia Art Institute of Padang Panjang, Jakarta Institute of Arts, LASALLE College of the Arts, Lucerne University of Applied Sciences and Arts, Mongolian State University of Arts and Culture, Musashino Art University, Nagoya University of Arts and Sciences, Plymouth University, RMIT University, Silpakorn University, Städelschule, The Central Academy of Fine Arts, University of California, Davis, and University of Washington

Tropical Lab is an annual international art camp and exhibition organised by LASALLE College of the Arts. Over two weeks, artists and students from major art schools and institutions present their work and undertake workshops and seminars addressing various aspects of history, geography, economics and aesthetics.

This year's edition explores the theme of citation: déjà vu. Déjà vu is a subjective instance of recollection which draws on personal experience or a sense of familiarity with a particular object, event or place. Déjà vu is often triggered by linguistic, olfactory, auditory and visual stimuli that recall past sensory experiences. In contemporary societies, how does technology affect our sense of having already seen or lived an event? The exhibition explores these sensations and ideas, and presents works in a range of media made during the camp by the twenty-six participants.

Tropical Lab is coordinated by Milenko Prvacki, Senior Fellow at LASALLE College of the Arts.

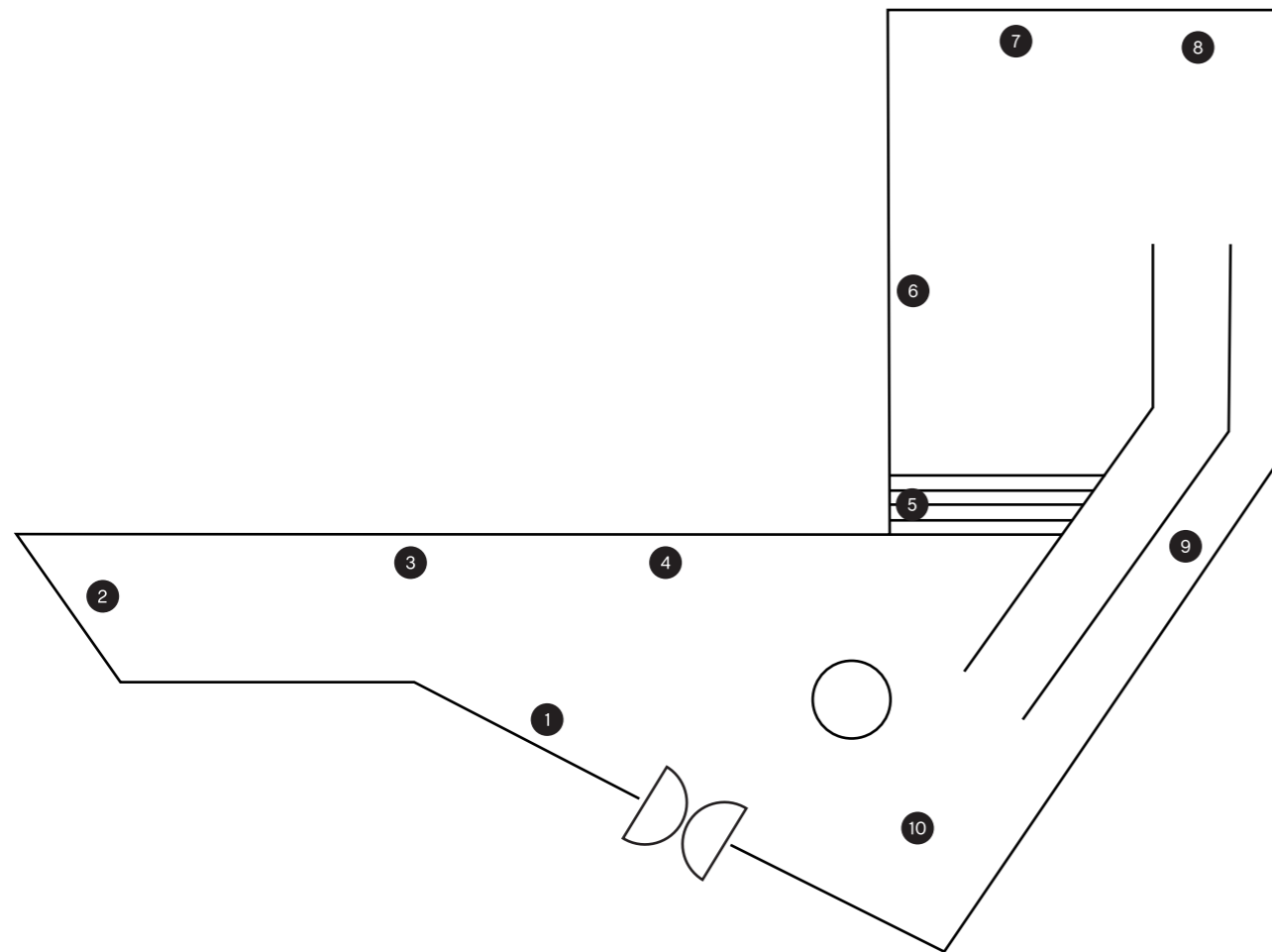

List of Works

Dimensions are given as height preceding width (followed, where applicable, by depth)

Brother Joseph McNally Gallery

- 1 Nadja Büttner
By law 2017
Perspex, sandpaper
80 x 18 x 18 cm

Note on process: The bottom 7 layers of this work are constructed from Perspex components that have been ground and polished by hand. Small pieces of sandpaper that carry residue from the grinding process are sandwiched between several of these layers. The second lowest group, made up of 13 layers, comprises Perspex components that have been ground and polished by machine. Two open spaces have been created within this group, and coloured Perspex sheets have been interleaved. The uppermost tier of 2 layers comprises components that have been polished by machine to the most refined finish possible.

- 2 Yu Chen
Red river 2017
cotton, thread, plastic buttons, objects given to the artist by Singaporean residents; adhesive vinyl
installation dimensions variable

- 3 Uchiyama Shiori
Record/Moment 2017
4 mirrors, 4 digital prints on burnt paper each displayed between 2 Perspex sheets, 4 light bulbs, fishing line; fibre-tipped pen on paper, pencil on graph paper, adhesive tape
installation dimensions variable

- 4 Stefan Tschumi
0.00000282 % 2017
2 digital prints
each 84 x 118 cm

- 5 Yukino Okumura
Dream walker 2017
digital animation displayed on monitor,
16:9 aspect ratio, colour, sound
6:10 minutes

- 6 Pauline Fabry

UOB Tower 2017
digital print
120 x 180 cm

Through movement 2017
3-channel, high-resolution digital video,
16:9 aspect ratio, colour;
audio recorded during a Hypno Hen Kai Pan lab led by the artist, Monday 24 July, 1:30 pm, Singapore
6:55 minutes

- 7 Duy Hoàng
Septal Nectary 2017
fluorescent lamps, water, food colouring, plants, plastic containers, wood, fabric, tools, measuring tape, wooden pegs, stickers, paper, scissors, paint brush, fibre-tipped pen, tweezers
203 x 245 x 122 cm

- 8 Jessie Wright
Prototype 2017
Perspex, metal hinges, foam, fabric (dimensions variable); lightbox (7.5 x 47.3 x 32.2 cm); 2-channel, high-resolution digital video displayed on 2 cathode-ray tube (CRT) television sets, 16:9 converted to 4:3 aspect ratio, colour
6 minutes

- 9 Emily Clark-Kramer
Where are you in it? 2017
handmade pop-up book
19 x 14 x 2.4 cm (closed)

- 10 Zoë Coughlan
To move, to know, to describe 2017
26 drop-moulded artists' tools in terracotta (each 20 x 30 x 1.5 cm approx.); water, glass tank (45 x 40 x 60 cm), fluorescent lamp
installation dimensions variable

All works courtesy the artists



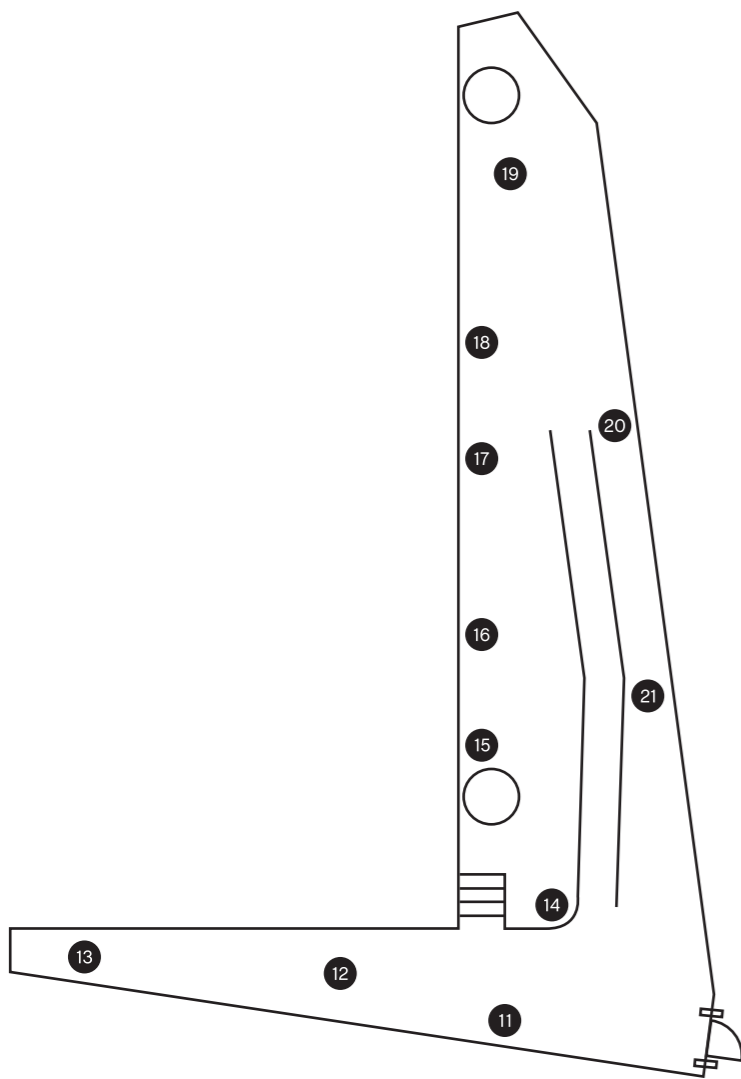

Praxis Space

- 11 Miho Otsuki
The notebook was named 'déjà vu' 2017
pencil, frottage, collage, ink and watercolour on 45 pages from artist's book; artist's book displayed on painted wooden table
installation dimensions variable
- 12 Aphinya Watheephakdee
Tying the memory 2017
fabric, found objects
dimensions variable
- 13 Cheryl Chiw
Serendipity 2017
iron oxide, neodymium magnet, steel fragments, steel sheet
57 x 335 x 65 cm

One, two, buckle my shoe 2017
single-channel, high-resolution digital video displayed on a cathode-ray tube (CRT) television set, 16:9 converted to 4:3 aspect ratio, black and white, sound
1 minute
- 14 Edi Danartono
Erinner dich (Journey to the East) 2017
polyester fabric, cotton, banana oil
80 x 60 x 35 cm
- 15 Anna Diehl
Ein Pferd ohne Reiter ist immer ein Pferd—ein Reiter ohne Pferd ist nur ein Mensch (A horse without a rider is always a horse—a rider without a horse is just a man) (to my friend) 2017
digital print on adhesive vinyl (58.21 x 130 cm), digital print on transparency mounted on Perspex (15 x 20 x 3 cm)
installation dimensions variable
- 16 Caitlyn Wilson
A fictive space-time 2017
charcoal, crayon, graphite and sumi ink on paper
130 x 302 cm

- 17 Lizzy Simpson
Detail of 'Water, water ...' from 'The rime of the ancient mariner' (1798) by Samuel Taylor Coleridge 2017
2-channel*, high-resolution digital video, 16:9 aspect ratio, colour, 2 minutes (approx.); earmuff

*1 channel is displayed in Praxis Space and 1 channel is displayed in Project Space
- 18 Harryaldi
In between 2017
single-channel, high-resolution digital video, 9:16 aspect ratio, colour, silent
1:50 minutes
- 19 Don Tinling
When Dorothy got to the Emerald City the Wizard of Oz protected the illusion 2017
rope, fabric; single-channel, high-resolution digital video displayed on monitor, 16:9 aspect ratio, colour, sound, 5:33 minutes
installation dimensions variable
- 20 Alain Pezard
Punjab and legs 2017
handwritten labels on 31 glass jars containing scents collected by participants and lecturers of Tropical Lab 11 in Singapore, elastic bands, leaves, paper, adhesive tape, plastic (each 9 x 2.8 x 5 cm approx.); fibre-tipped pen and digital print on 30 paper sheets (each 21 x 14.8 cm, folded)
installation dimensions variable
- 21 Alain Pezard
From July 19th to August 3rd 2017
objects found, given to, or bought by the artist and the participants in Tropical Lab 11
installation dimensions variable

All works courtesy the artists

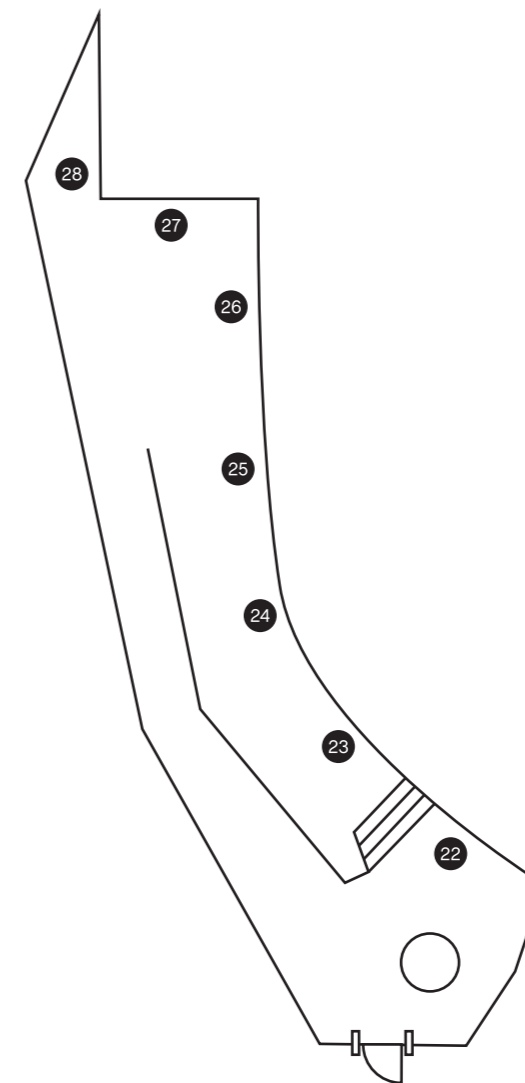

Project Space

- 22 Sara Stern
Deluxe in the walls (high-end haunt) 2017
Ice Mountain cardboard box (27 x 41 x 23 cm) single-channel, high-definition digital video, 16:9 aspect ratio, colour, sound
2:50 minutes
- 23 Nandin-Erdene Budzagd

Left to right:

Untitled 2017
collage, synthetic polymer paint and charcoal on card
84 x 60 cm

Portrait 1 2017
collage, synthetic polymer paint and charcoal on card
60 x 42 cm

Portrait 2 2017
collage, synthetic polymer paint and charcoal on card
60 x 42 cm
- 24 Ambra Viviani
Abstract from the post exoticist pavilion 2017
synthetic polymer paint on wall ('alpine' colour), steel, Perspex, lemon, green chillis
300 x 300 x 35 cm (approx.)
- 25 Julia König
A new line of defence 2017
pigment on polystyrene and rubber
240 x 160 x 5 cm
- 26 Lizzy Simpson
Detail of 'Water, water ...' from 'The rime of the ancient mariner' (1798) by Samuel Taylor Coleridge 2017
2-channel*, high-resolution digital video, 16:9 aspect ratio, colour, 2 minutes (approx.); earmuff

*1 channel is displayed in Praxis Space and 1 channel is displayed in Project Space
- 27 Satya Cipta
SOMYA 2017
single-channel, high-resolution digital video projection, 16:9 aspect ratio, colour, sound
2:43 minutes
- 28 Brenda Tan
But what if 2017
25 cigarettes, polyvinyl acetate
installation dimensions variable

All works courtesy the artists