

BA(HONS) PRODUCT DESIGN: RELENTLESS

Institute of Contemporary Arts Singapore
Brother Joseph McNally Gallery
LASALLE College of the Arts
9–28 March 2019

Relentless presents selected works and texts by students from all three levels of the BA(Hons) Product Design programme. The exhibition presents the creative inquiries and 'failures' of the students during the design process.

In design exhibitions, emphasis is often placed upon finished products. *Relentless* invites visitors to explore the development of products through materials, models and texts. The exhibition demonstrates the importance of experimentation in design: by trialling different ideas, the students not only tested the scope of different structures, but also created entirely new products. The title of the exhibition reflects their consistent attempts to improve their designs.

Sketches and texts describing materials and theses are displayed on the gallery walls. Tables connected to resemble an assembly line snake through both levels of the gallery. On the tables are models and materials used by the students throughout the design process.

Academic leads: Daniel Ayapillai, Lecturer, School of Product and Spatial Design; Dhiya Rahman, Part-time Lecturer, School of Product and Spatial Design and McNally School of Fine Arts ICA Singapore coordinating curator: Melanie Pocock

#relentless
#SoSPD

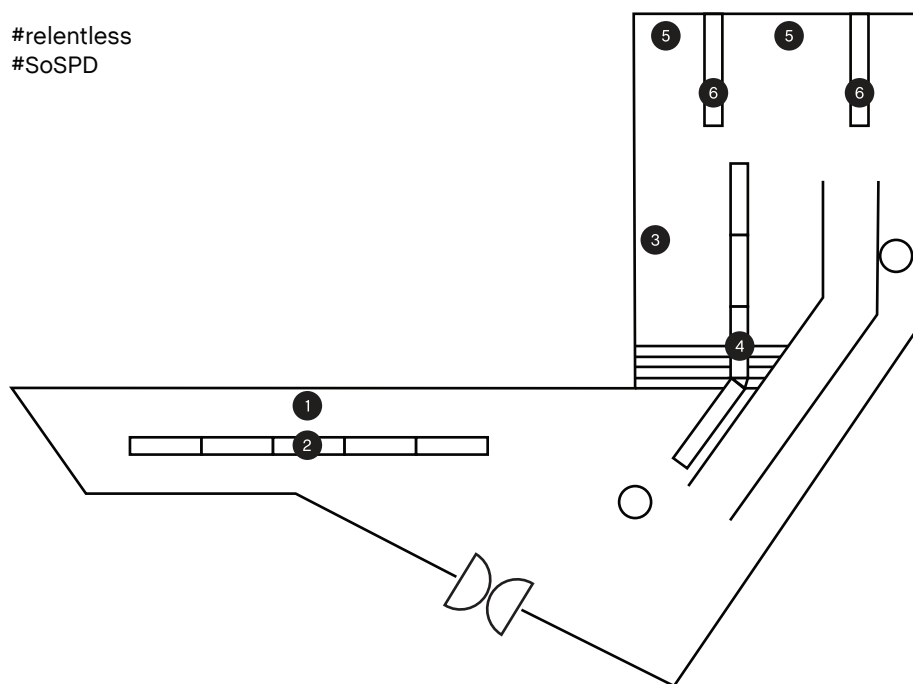

BA(Hons) Product Design

Level 1

Benjamin Tan De Jun, Chen Zhi Hao, Cheong Jun Hong, Christyla Susanto, Edwin Fong Jing Han, Firna Fadya Hayya, Gabriela Samantha, Goh Joon Hean Darren, Ho Su Yu, Lee Cheng-Kang, Leong Ying Jia, Nicole, Mok Justin, Ng Yan Teng, Nicholas Bee Yuan Zhi, Ong Wei Ning, Poh Xuan Qing, Steven Ray Kurniawan, Su Su Rati, Teo Jie Huey, Vibhor Jain, Wynnes Beh Kai Yi

Level 2

Abraham Ayrookuzhiyil Yohaana, Abhavaya Roshan, Aisyah Binte Azhari, Benjamin Lee Jian Hui, Chien Wen Xiong, Chow Pei Jun, Chong Jo Ee, Chong Zhuo Min, Darius Loh Yeok Teng, Harith Norsyahmi Bin Normissham, Omez Esther Romane Alizee, Joane Nathasya Saraswati, Joel Khoo, Koh Hong Pin, Kennerve Tan, Ker Kai Li, Mai Yuyan, Molly Tan Li Joo, Mohamed Hisyamuddin bin Mohamed Hussain, Shruti Kaul, Tanvi Bihani, Tay Wei Cong Ryan, Teo Jun Hui, Varsha Sankar, Tan Xin Yi, Yashika Luthra, Lim Yong Xiang

Level 3

Abdullah Mustaffa, Vanessa Ang, Sakshi Bajaj, Tithi Bhatt, Daphne Chan, Chen Jie, Tim Chen, Srijani Chowdhury, Henny Dwi Rachmawati, Shruti Gunupuru, Kay Jinzi, Arzoo Kapoor, Alex Kuik, Jacinda Lau, Lau Kuan Ee, Hanmi Lee, Amos Lim, Lim Chin Hock, Lim Jun Ze, Joey Lim, Kevin Lim, Purvi Maheshwari, Gauri Nair, Jaren Neo, Nur Yani, Ong Zi Kai, Seul Sunho, Timothy, Tung Joey, Wang Chen Hui

List of works

Dimensions are given height preceding width (followed, where applicable, by depth)

- 1 Texts describing materials by Level 1 students, 2018–19
7 digital prints, tape
each 59.4 x 42 cm
- 2 Products, prototypes and notebooks by Level 1 students, 2018–19
wood, paper, cardboard, metal, plastic, glass, tape, ink on paper, fibre-tipped pen on paper
various dimensions and pages
- 3 55 sketches by Level 2 students, 2018–19
ink on paper, pencil on paper, fibre-tipped pen on paper, tape
various dimensions
- 4 Prototypes by Level 2 students, 2018–19
plastic, wood, paint on wood, resin, metal, glass, electronics, batteries, foam, aluminum foil on cardboard
various dimensions
- 5 Posters, photographs and summaries of dissertation theses by Level 3 students, 2018–19
58 digital prints, tape
various dimensions
- 6 Prototypes and materials used by Level 2 students, 2018–19
concrete, wood, metal, plastic, foam board, plaster, resin, cardboard, reed, thread, tape
various dimensions